

TOOL DATA SHEET

www.chasediamond.com

www.chase-technology.com

Tel: +44 (0) 1536 461133 Fax: +44 (0) 1536 461144



Chase Diamond Tools International Ltd

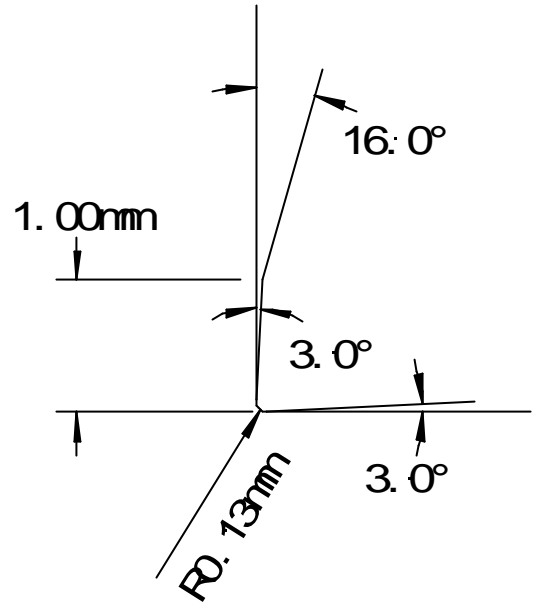

Tool Number	
Tool Type	Micro Turning Tool (Roughing or Finishing)
Form	Solid Shank or Insert
Shank	6mm Square x 50mm length (Specified)
Insert Type	CPGW 05T102 FN DX2
Diamond Material	Natural
TOOL GEOMETRY	
Radius	0.001" to 0.010" increments of 0.001" (0.0254mm – 0.254mm)
Front Clearance Angle	1 – 15 degrees
Front Clearance Type	Cylindrical
Top Rake Angle	0 to -2 degrees
Included Angle	Specified
Controlled Waviness	-
Arc Radius	-
Chip free magnification	800 x